



M-Light range

MLHE/170jis LED Ø 170 mm Head light



- **LED Headlight with PAR56 mechanical interface**
- **Compatibility with all PAR56 Bulbs for retrofit**
- **Enhanced optical performances**
- **Long service life (full LED technology)**
- **Conform to US FRA Regulation & Indian Railways**



Standards:

- Design Conform FRA Regulation 49 CFR229.125
- Application EN 50155
- EMC EN 50121-3-2
- Product EN 61373
- Environment EN 60068, EN 60529
- Fire/smoke NFPA130

Mechanical / Environmental characteristics:

- PAR56 mounting
- Protection: IP66 front and rear
- Operating temperature: -40°C / +70°C
- Protective glass
- Cable EN 50306-4 connection
- Shock resistance: IK09
- UV resistant

Electrical characteristics:

- Power supply : 72 Vdc (-30% /+20%)
- Optimized power consumption
- Long service life : 60 000 h

Optical characteristics:

- Ø170 mm lit area

	49 CFR229.125		Mafelec
	Intensity (Cd)	Intensity (Cd)	Mean consumption (W)
Head light full mode	> 200 000 cd	> 280 000 cd	< 50W
Head light Dimmed mode	-	> 140 000 cd	< 20W

Values can be adapted on request

Dimensions:

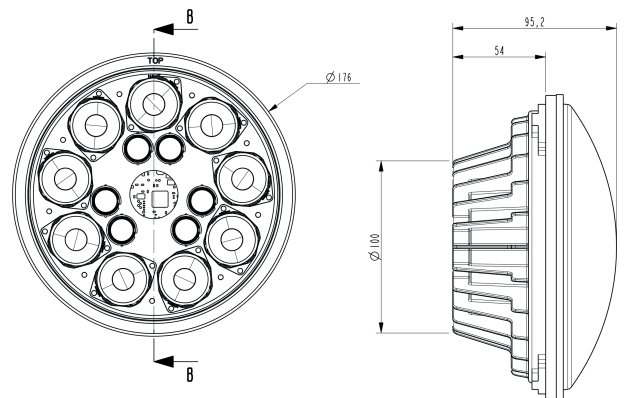

Options:

- Light status feedback (potential free contact)
- Glass protective glass (for robustness against chemicals)
- Customized connector and cable length
- Mechanical interface mounting plate
- Defrosting
- Anti glare system



AEROSPACE & DEFENCE



COACHES & BUSES



RAILWAY



INDUSTRY



ENERGY



PLEASURE BOAT



VERTICAL TRANSPORT



INDUSTRIAL VEHICLES



OFFSHORE & MINING